

Description

The Basic Atom Super Development Board is designed for use in robotic applications which need higher power and I/O for motors and sensors. The Super development board includes a power led, 5 volt regulator circuit, easy PC serial port programming interface, reset button 4 servo connectors with VDD or VIN selector, solderless prototyping area. The Super Development Board supports the Basic Atom 24, 28 and 40 pin modules..

Power Connections

The development board requires a 2.1mm center positive connector. The recommend power rating is 12 volts at 500mA. The development boards uses a LM2940 power regulator which can supply up to 1 Amp max. Exceeding 1 Amp may cause damage to the power regulator.

There is an additional power connector for battery applications. 4 pins in total. The two center pins are not connected. The VDD and VSS pins are marked on the development board. The connector is ideal for battery packs or quick disconnect power sources.

Orientation

The Basic Atom 24, 28 and 40 pin modules should only be inserted in there correct orientation. The Basic Atom should be aligned from the S_OUT pin to the socket position clearly marked pin one. All Basic Atom modules Start to the front of the 40 pin socket marked pin one.

Atom Development Board and Servos

The Atom development board can support up to 4 small servo. There is the option of powering the servo motors from VDD or VIN. Powering the servo motor from VDD draws its power from the +5 volt regulator which has a maximum of 1 Amp. Larger servo motors or large loads the VIN option is better. VIN draws its power directly from the power adapter connected to the board. If VIN is used to power the servo motors, caution should be taken as to what voltage and milliampere the power supply is. You should match the ratings of the power adapter to the voltage and draw of the servo motors, keeping in mind the maximum input to the development board should not exceed 16 volts at 500mA.

To control each servo on the development board use the servo command with the pin number associated by the connector.

```
Servo 12, 1000 ;rotate servo at SR1
Servo 13, 1000 ;rotate servo at SR2
Servo 14, 1000 ;rotate servo at SR3
Servo 15, 1000 ;rotate servo at SR4
```

Each pin is used to control one servo located on jumper SRx. If a servo is connected to any of the SRx jumpers then its associated pin can only be used to control the servo.

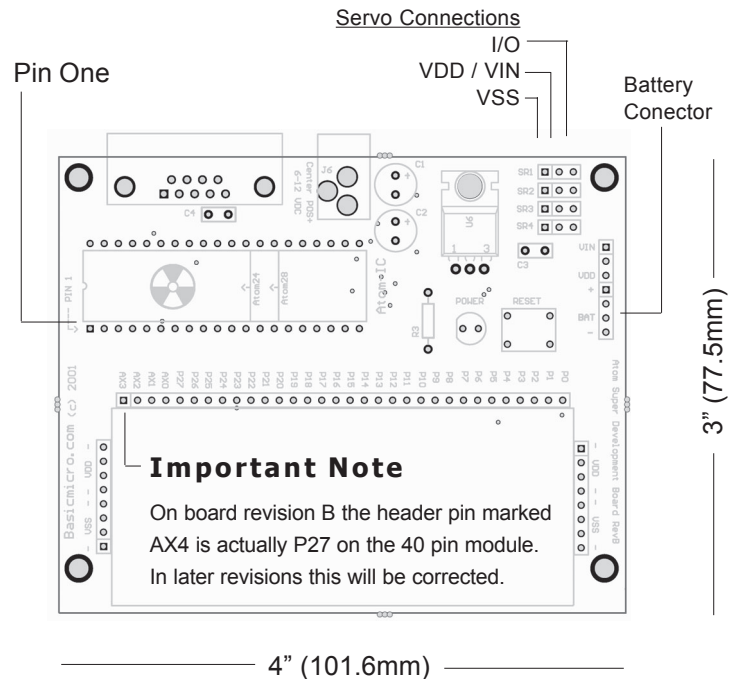

Schematic

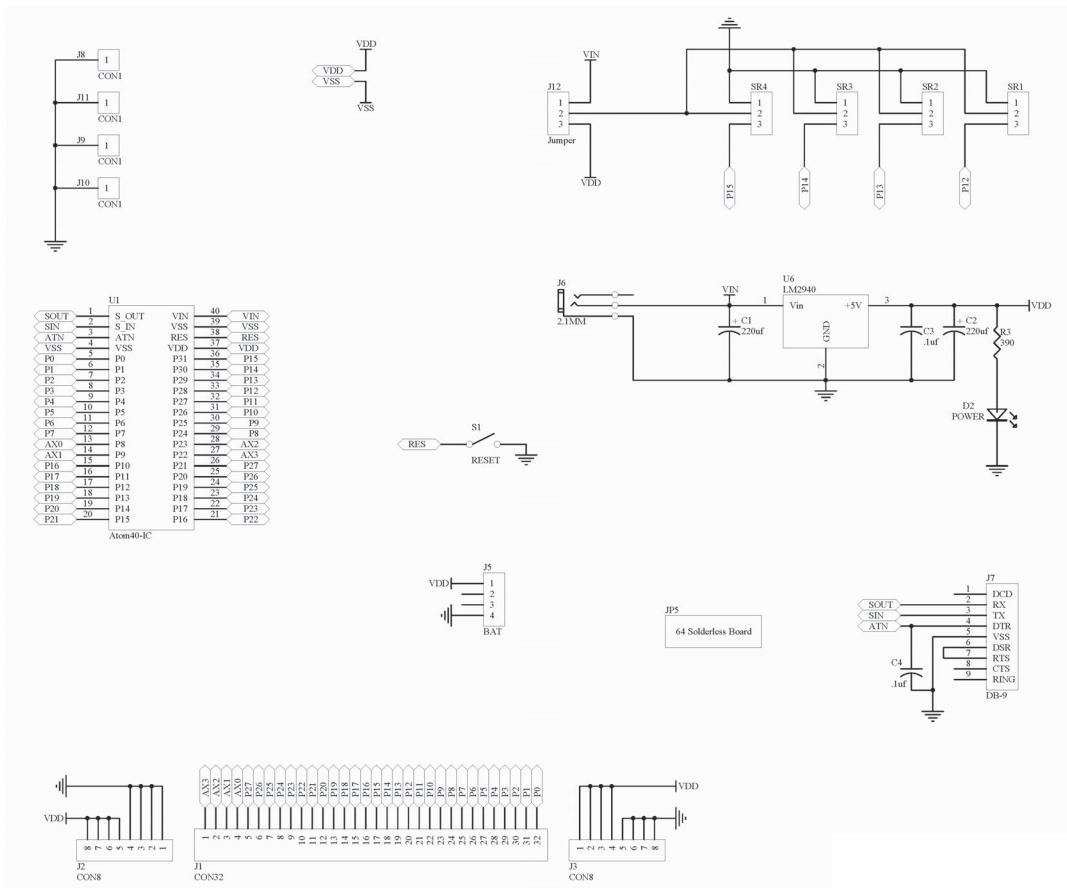

Warranty

Basic Micro warranties its products against defects in material and workmanship for a period of 90 days. If a defect is discovered, Basic Micro will at our discretion repair, replace, or refund the purchase price of the product in question. Contact us at support@basicmicro.com No returns will be accepted without the proper authorization.

Copyrights and Trademarks

Copyright© 1999-2001 by Basic Micro, Inc. All rights reserved. PICmicro® is a trademark of Microchip Technology, Inc. The Basic Atom and Basic Micro are registered trademarks of Basic Micro Inc. Other trademarks mentioned are registered trademarks of their respective holders.

Disclaimer

Basic Micro cannot be held responsible for any incidental, or consequential damages resulting from use of products manufactured or sold by Basic Micro or its distributors. No products from Basic Micro should be used in any medical devices and/or medical situations. No product should be used in a life support situation.

Contacts

Email: sales@basicmicro.com, Tech support: support@basicmicro.com, Web: <http://www.basicmicro.com>

Discussion List

A web based discussion board is maintained at <http://www.basicmicro.com>

Technical Support

Technical support is made available by sending an email to support@basicmicro.com. All email will be answered within 48 hours. All general syntax and programming question, unless deemed to be a software issue, will be referred to the on-line discussion forums.