



BASIC MICRO

TECHNOLOGY AT WORK

**B0088 - Zeus Mini 3A Switching Regulator
Data Sheet**

Feature Overview:

- 3 Amp Switching Regulator
- High Efficiency Regulation
- Thermal Protection Built-In
- Up To 30V Input
- Output From 2V to 13V
- Pin Compatible With 78xx Regulators
- Worm Screw Adjustable Pot
- Access To All I/O From Header
- BEC (Battery Eliminator)
- Screw Terminal For Direct Battery Input

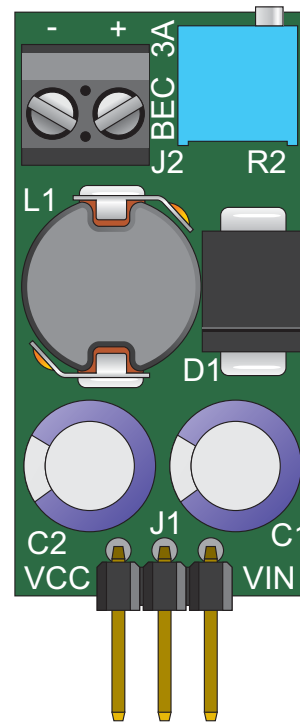
**Description**

Light weight and compact the Zeus Mini is the ideal low cost 3A Switching Regulator. Its the perfect solution to eliminate a second battery or power source. Now you can power your robots, servos, microcontroller and electronics from a single battery or power source up to 30VDC. The Zeus Mini requires no electronics experience. Adjustable from 2V to 13V and anywhere in between.

Applications

The Zeus Mini is ideal for small space applications, solderless bread boards or as a BEC (Battery Elimination Circuit). The Zeus Mini is pin compatible with a common 78xx linear voltage regulators making it an easy drop in replacement for your next project. The Zeus Mini can be used as convenient 3.3V DC to DC converter.

Hardware Overview:

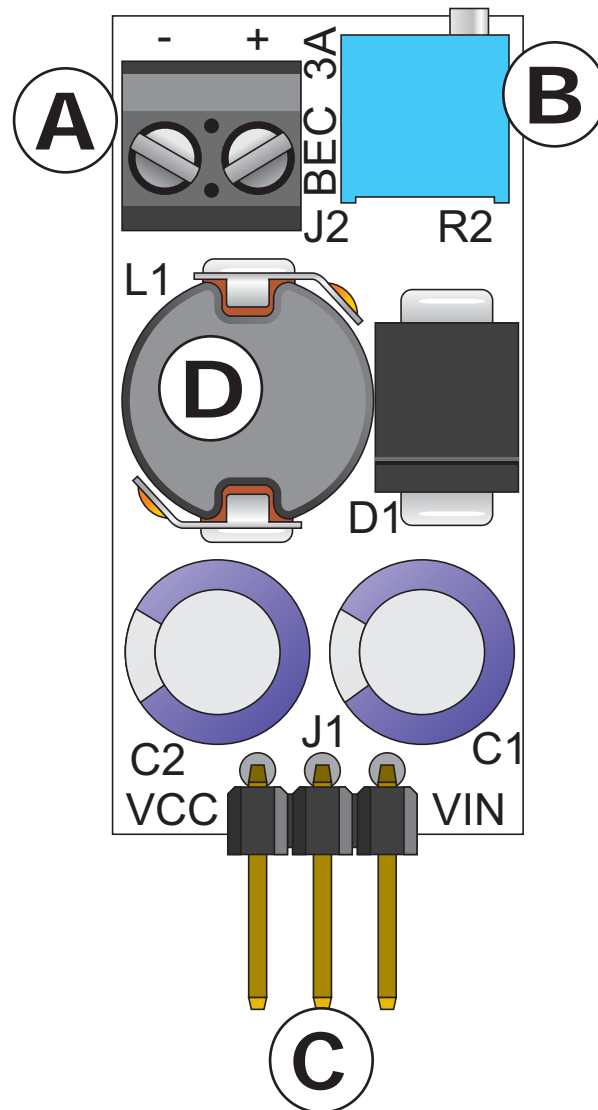

- A:** 3.5mm Power Input Screw Terminals
- B:** Voltage Output Adjustable Potentiometer
- C:** 3 Pin Output
- D:** Inductor

Input Voltage

The input voltage to the Zeus Mini can be supplied from the 3.5mm screw terminals or to the 3 pin header at the bottom. The Zeus Mini 3 pin header is pin compatible with any 78xx variant linear regulator. It can be used as a drop in replacement or in a solderless bread board.

The input voltage should not exceed 30V. The high efficiency of the regulator will generate little heat even when the voltage is stepped down from 30V to 2V. However since the regulator can handle up to 3 Amps, a step down from 30V to 2V will likely require an additional heat sink if maximum current is required.

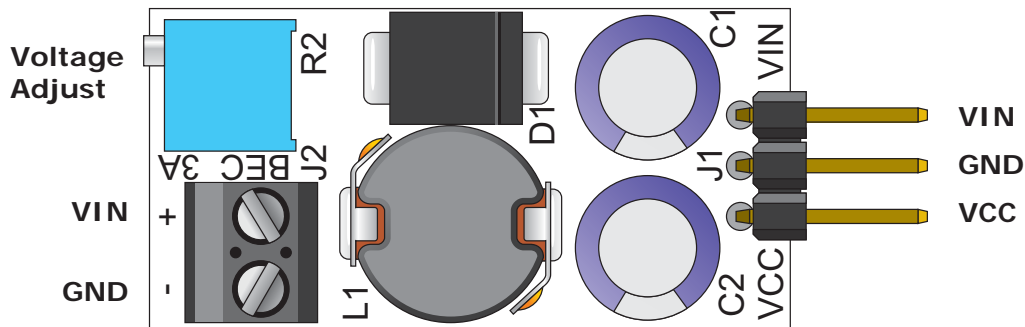

Output Voltage

The output voltage is set by R2 the on board potentiometer. A worm screw type potentiometer is used to prevent the Zeus Mini from changing voltages due to vibration. The output voltage can be adjusted by 100th of a volt increments. When adjusting the output voltage apply input power. Use a standard multi meter connected to VCC on the 3 pin header. Set the multi meter to DC. As the potentiometer is turned you will see the voltage increase or decrease. Go slowly giving the on board capacitors time to adjust. Otherwise you can easily overshoot the desired voltage.

Heat Sinking

Depending on the voltage drop the Zeus Mini may need additional heat sinking for U1 on the back side. A voltage drop from 12V to 5V at 1Amp would run warm but additional heat sinking would not be required. Heat sinking will also depend on the Zeus Mini's location. The on board switching regulator has built in thermal protection. In case of an over heat the regulator will shut down automatically until a normal operating temperature is restored.

Dimensions:

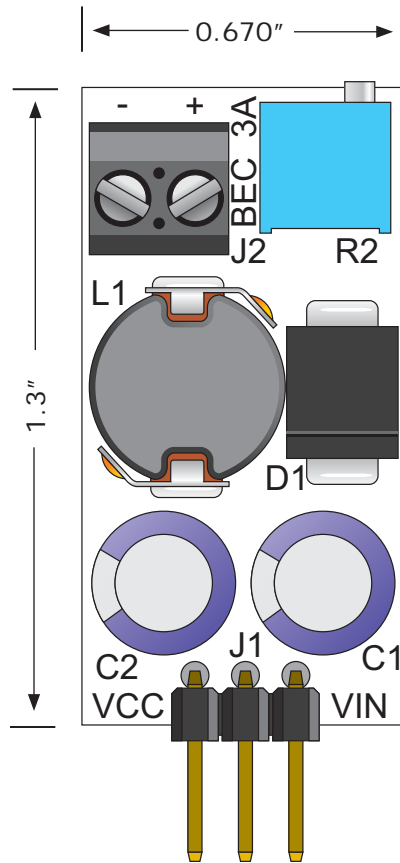

Board Edge: 0.670"W X 1.3"L

Electrical Characteristics

| Characteristic | Rating | Min | Max |
|-----------------|--------|-----|------|
| VCC Input | VDC | 5 | 30 |
| Current Draw | mA | 10 | 3000 |
| Tempature Range | C | -40 | +125 |

Warranty

Basic Micro warrants its products against defects in material and workmanship for a period of 90 days. If a defect is discovered, Basic Micro will, at our discretion, repair, replace, or refund the purchase price of the product in question. Contact us at support@basicmicro.com. No returns will be accepted without the proper authorization.

Copyrights and Trademarks

Copyright© 2010 by Basic Micro, Inc. All rights reserved. PICmicro® is a trademark of Microchip Technology, Inc. The Basic Atom and Basic Micro are registered trademarks of Basic Micro Inc. Other trademarks mentioned are registered trademarks of their respective holders.

Disclaimer

Basic Micro cannot be held responsible for any incidental, or consequential damages resulting from use of products manufactured or sold by Basic Micro or its distributors. No products from Basic Micro should be used in any medical devices and/or medical situations. No product should be used in a life support situation.

Contacts

Email: sales@basicmicro.com
Tech support: support@basicmicro.com
Web: <http://www.basicmicro.com>

Discussion List

A web based discussion board is maintained at <http://www.basicmicro.com>.

Technical Support

Technical support is made available by sending an email to support@basicmicro.com. All email will be answered within 48 hours. All general syntax and programming questions, unless deemed to be a software issue, will be referred to the on-line discussion forums.