



BASIC MICRO

TECHNOLOGY AT WORK

**BasicATOM Nano 8
Data Sheet**

Feature Overview:

- 3 KB of program space (FLASH)
- 80 Bytes of user memory (RAM)
- 5 Input / Output Pins
- 5V Input / Output Pins
- No External Components Required
- Internal Resonator
- 4 Analog-to-Digital Capable I/O Pins
- Capture Compare Hardware
- Hardware PWM
- Hardware Interrupts
- Software Serial up to 38400 Baud
- 32 Bit Floating Point Math
- 32 Bit Integer Math
- Over 13,200 BASIC Instructions Per Second

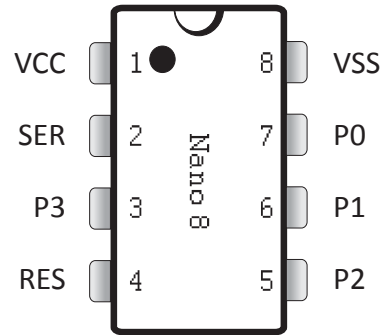
**Basic Description**

The BasicATOM Nano 8 is an easy to use BASIC programmable microcontroller. It is built on the Microchip PIC12F617 processor and is designed to be software compatible to both BasicATOM and Basic Stamp line of modules. The BasicATOM Nano 8 does not require any additional components code is highly optimized and in most cases faster than comparable products.

Documentation

The BasicATOM Nano 8 uses the same development tools and language as the BasicATOM and BasicATOM Pro modules. Timings for certain commands will be different slightly. Refer to the manual for additional details. Most application notes or sample code for the BasicATOM can be run without modification on the BasicATOM Nano series.

Pin Name Assignment Overview

Pin Name	Description
RES	Active-low reset. Pin is set high with 10K pull-up resistor to run.
SER	Programming pin. Bidirectional I/O.
VCC	Regulated 5VDC input.
VSS	Ground (GND)
P0	<ul style="list-style-type: none">• General purpose I/O Pin.• Interrupt pin.• Analog capable.
P1	<ul style="list-style-type: none">• General purpose I/O Pin.• Interrupt pin.• Analog capable.
P2	<ul style="list-style-type: none">• General purpose I/O Pin.• Interrupt pin.• Hardware PWM Output.• Analog capable.
P3	<ul style="list-style-type: none">• General purpose I/O Pin.• Interrupt pin.• Analog capable.

Programming Interface

The BasicATOM Nano can be programmed using several methods. The Nano uses a single bidirectional I/O pin for programming. A typical RS232 circuit or USB to Serial adapter like the Nano USB2Serial adapter can be used.

Nano USB2Serial Adapter Connections

The Nano USB2Serial adapter only requires 3 connections. Pin 2 of the Nano which is the Serial pin, connects to the SER pin of the programmer. Pin 4 of the Nano is the RESET control pin and should be connected to the RES pin of the programmer. Pin 8 of the Nano is the ground pin VSS and should be connected to a shared ground (GND) with the programmer.

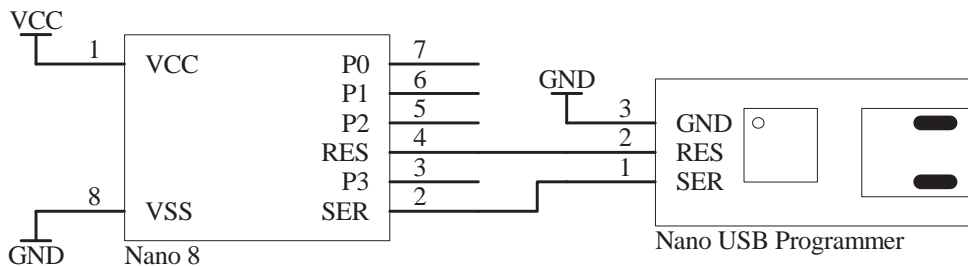

Nano RS232 Programmer Interface

The Nano uses a single bidirectional I/O pin for programming. The circuit shown uses common parts. The 10K resistors and diode used in the programming circuit can be purchased from Basicmicro or found locally at RadioShack.

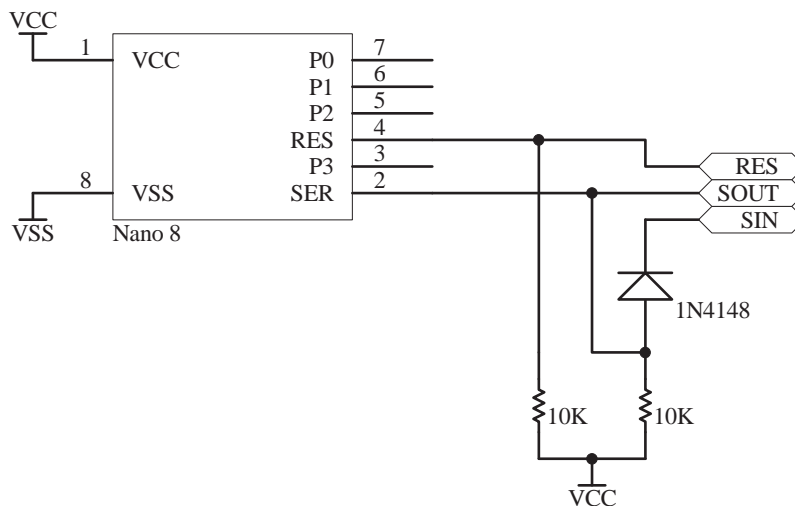

Solderless Breadboard Programmer Circuit

The Nano programming circuit is very simple and is shown on a solderless breadboard. The Nano reset pin (RES) must be pulled up with a 10K resistor and is required to run the Nano. The second resistor and diode make up the programming circuit which allows the Nano to use only one pin for programming. A filter capacitor of around 0.1uf is recommended to reduce any noise on the power. The cap is placed close to the Nano and connected to 5VDC and GND.

Important

The supply voltage can not exceed 5VDC or damage will result. Never interrupt the programming process or damage will result.

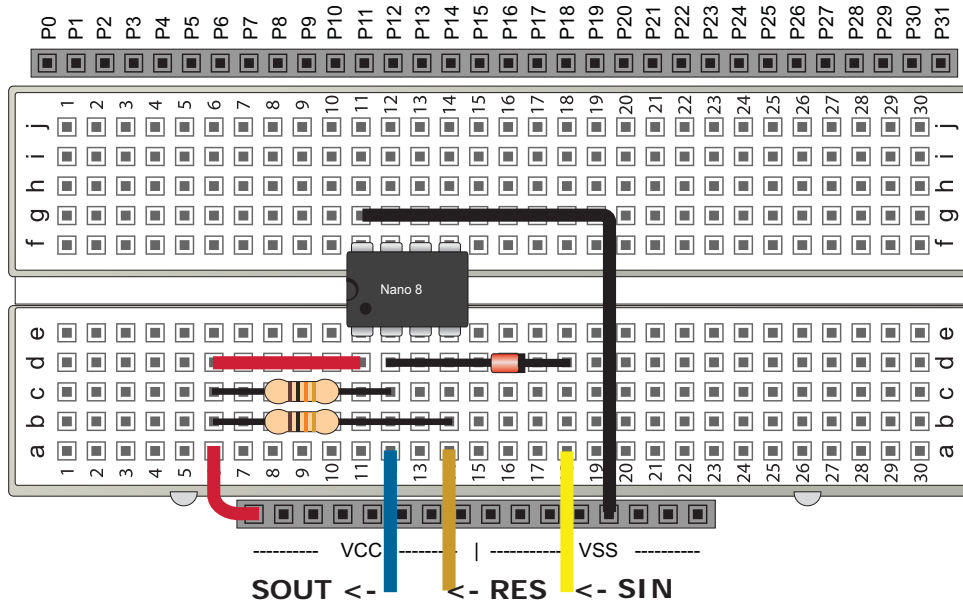

SIN, SOUT and RES

RES from the Nano must be connected to RTS of the RS232 circuit or USB2Serial adapter. SOUT is connected to the RX (receive) pin and SIN is connected to the TX (transmit) pin of the RS232 circuit or USB2Serial adapter.

Electrical Characteristics

Characteristic	Value (Units)
VCC Range (min - max)	4.9 - 5.2VDC
Current Draw (Sleep mode)	< 1 mA
Current Draw (Idle)	1 mA
I/O Voltages (Low / High)	0.0 V / 5.0V
I/O Logic	TTL
I/O Pin Assignments	P0-P3, SER
I/O Maximum Current	25 mA sink, 25 mA source Note: Total current for all pins should not exceed 90 mA sink and 90 mA source
Memory (RAM)	80 Bytes
Memory (Flash)	3 KB
Tempature Range	-40 to +125 C

Warranty

Basic Micro warranties its products against defects in material and workmanship for a period of 90 days. If a defect is discovered, Basic Micro will, at our discretion, repair, replace, or refund the purchase price of the product in question. Contact us at support@basicmicro.com. No returns will be accepted without the proper authorization.

Copyrights and Trademarks

Copyright© 2008 by Basic Micro, Inc. All rights reserved. PICmicro® is a trademark of Microchip Technology, Inc. The Basic Atom and Basic Micro are registered trademarks of Basic Micro Inc. Other trademarks mentioned are registered trademarks of their respective holders.

Disclaimer

Basic Micro cannot be held responsible for any incidental, or consequential damages resulting from use of products manufactured or sold by Basic Micro or its distributors. No products from Basic Micro should be used in any medical devices and/or medical situations. No product should be used in a life support situation.

Contacts

Email: sales@basicmicro.com
Tech support: support@basicmicro.com
Web: <http://www.basicmicro.com>

Discussion List

A web based discussion board is maintained at <http://www.basicmicro.com>.

Technical Support

Technical support is made available by sending an email to support@basicmicro.com. All email will be answered within 48 hours. All general syntax and programming questions, unless deemed to be a software issue, will be referred to the on-line discussion forums.