



# **BASIC MICRO**

TECHNOLOGY AT WORK

**BasicATOM Pro One-M  
Data Sheet**

**Feature Overview:**

- 32 KB of Program Space (FLASH)
- 2 KB of User Memory (RAM)
- 8 Input / Output Pins
- Built-in 5V Regulator
- RS232 Port for In-Circuit Serial Programming
- 4 Analog-to-Digital Capable I/O Pins
- Hardware Serial Port 256 Byte Buffer
- 3 Hardware Timers
- 3 Hardware PWM I/O Pins
- Hardware Interrupts
- 8 Servo Background Control
- 32 Bit Floating Point Math
- 32 Bit Integer Math
- 0.5us Timing Resolutions
- Over 100,000 BASIC Instructions Per Second

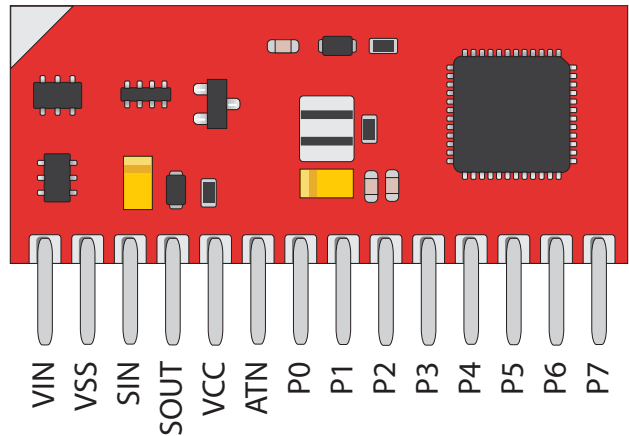

**Basic Description**

The BasicATOM Pro One-M is a microcontroller designed for demanding embedded system use. It is built upon the Hitachi HD64F3694GFYV processor and is designed to be pin-compatible to the Basic Stamp 1 line of modules.

**Hardware Overview:**

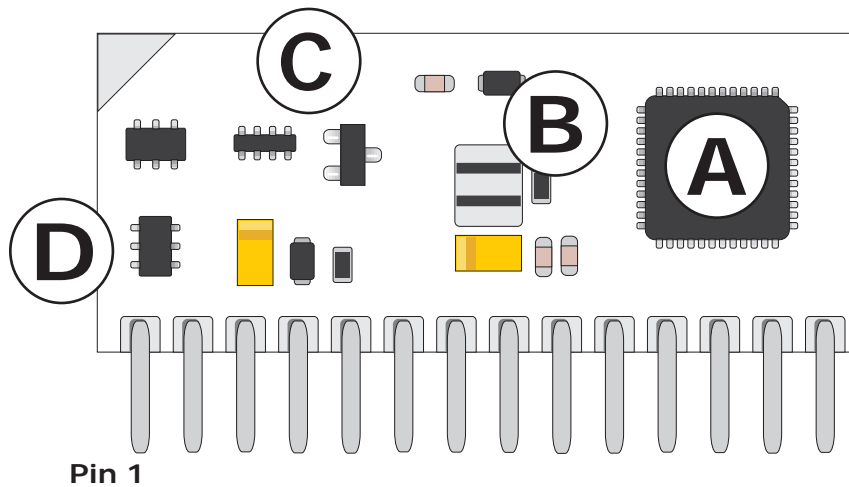

- A:** BasicATOM Pro CPU (Hitachi HD64F3694GFYV). Stores and executes program code.
- B:** Resonator circuit. Generates primary clock for CPU.
- C:** RS232 level shifting circuit. This allows the BasicATOM Pro to connect directly to a PC.
- D:** Power regulator. Input 6 to 9VDC.

## Pin Assignment Overview

Pin	Description
P0	<ul style="list-style-type: none"> <li>• General purpose I/O Pin.</li> <li>• Analog to Digital (A/D) AN0.</li> <li>• Interrupt input pin WKP0 (low enabled).</li> </ul>
P1	<ul style="list-style-type: none"> <li>• General purpose I/O Pin.</li> <li>• Analog to Digital (A/D) AN1.</li> <li>• Interrupt input pin WKP1 (low enabled).</li> </ul>
P2	<ul style="list-style-type: none"> <li>• General purpose I/O Pin.</li> <li>• Analog to Digital (A/D) AN2.</li> <li>• Interrupt input pin WKP3 (low enabled).</li> </ul>
P3	<ul style="list-style-type: none"> <li>• General purpose I/O Pin.</li> <li>• Analog to Digital (A/D) AN3.</li> <li>• Interrupt input pin WKP3 (low enabled).</li> </ul>
P4	<ul style="list-style-type: none"> <li>• General purpose Input / Output Pin.</li> <li>• Interrupt input pin WKP4 (low enabled).</li> <li>• FTIOD: Capture Compare Pin.</li> <li>• PWM Output Pin D for Timer W.</li> </ul>
P5	<ul style="list-style-type: none"> <li>• General purpose I/O Pin.</li> <li>• Interrupt input pin WKP5 (low enabled).</li> <li>• Analog to Digital (A/D) Trigger input. Low enabled. ADTRH.</li> <li>• FTIOC: Capture Compare Pin.</li> <li>• PWM Output Pin C for Timer W.</li> </ul>
P6	<ul style="list-style-type: none"> <li>• General purpose I/O Pin.</li> <li>• 3.3V Output only. 5V tolerant input.</li> <li>• Interrupt input pin.</li> <li>• Hardware I2C Data input pin (SDA). Pull-up resistance is required when using I2C.</li> <li>• FTIOB: Capture Compare Pin.</li> <li>• PWM Output Pin B for Timer W.</li> </ul>
P7	<ul style="list-style-type: none"> <li>• General purpose I/O Pin.</li> <li>• 3.3V Output only. 5V tolerant input.</li> <li>• Interrupt input pin.</li> <li>• Hardware I2C Clock pin (SCL).</li> <li>• FTIOA: Capture Compare Pin.</li> </ul>

Pin Assignment Overview

Pin	Description
SOUT	Programming output pin (connects to RS232 RX pin).
SIN	Programming input pin (connects to RS232 TX pin).
ATN	Active-High reset signal for programming (Connects to RS232 RTS pin).
VSS	Ground (GND)
VCC	Regulated power input / output. 5 VDC 50 mA output. 5VDC 100 mA input.
VIN	Unregulated power input. 9 VDC maximum input.

Programming Interface

The BasicATOM Pro One-M can be programmed from a simple RS232 serial programming interface. Only 4 connections to a RS232 DB9 cable are required.

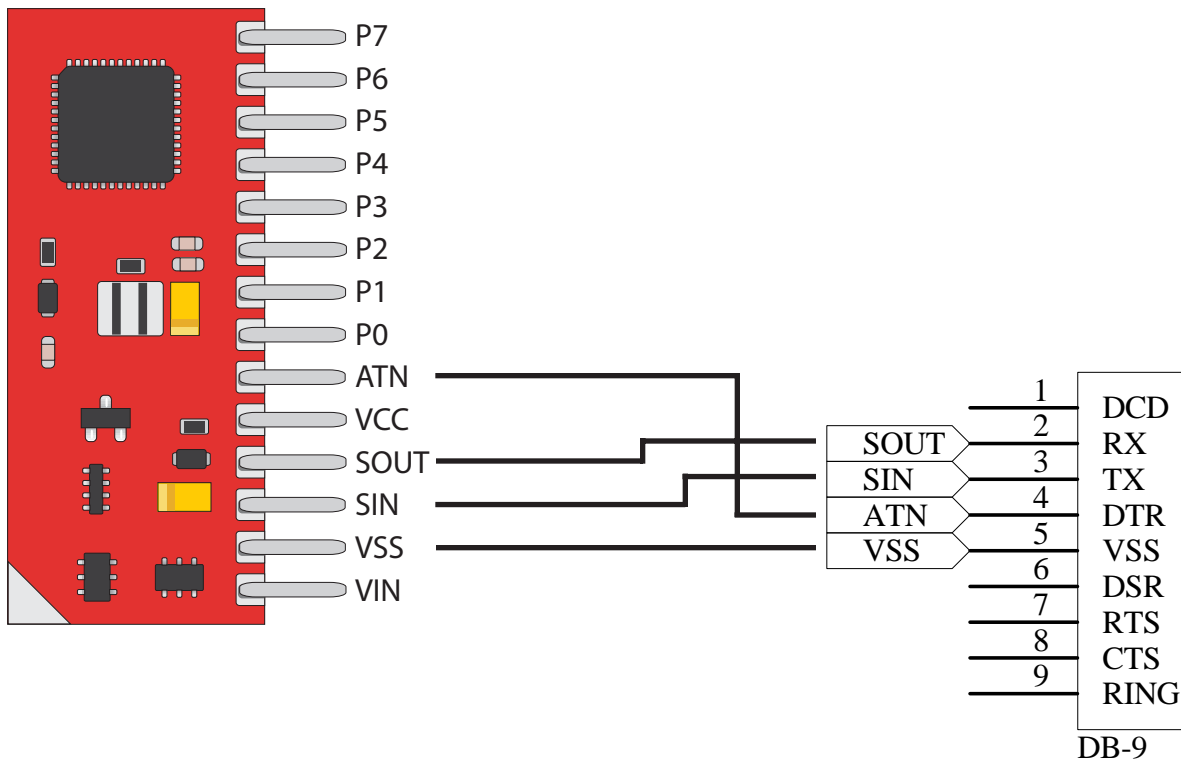

**USB Programming Interface**

The FTDI FT232RL USB to serial microcontroller is recommended for your own custom designs requiring an USB interface. The schematic is setup for bus power. The FTDI is powered when plugged into a USB port. You will need to power the module separately through a normal power regulator.

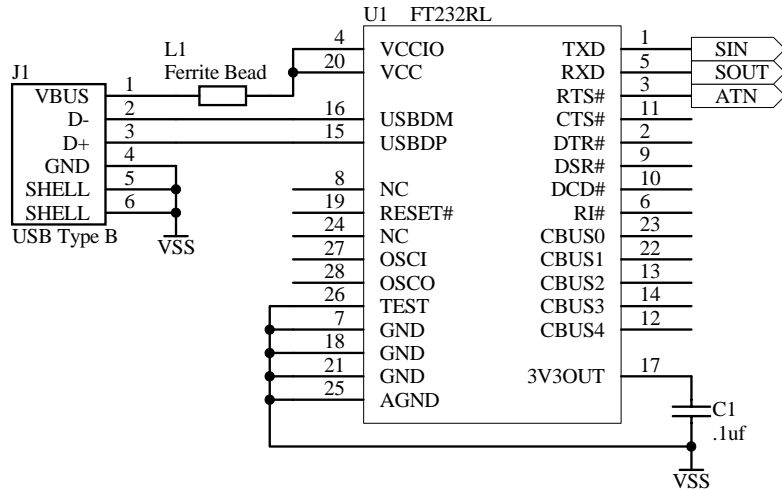

**RS232 Cable Pinout**

Below are pinouts for both male and female RS232 DB-9 cabling.

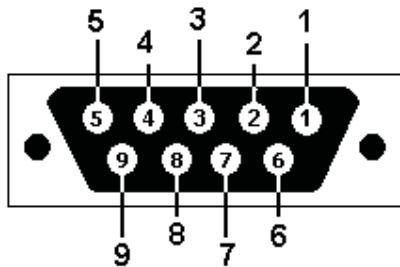

DB9 View Looking into Female Connector

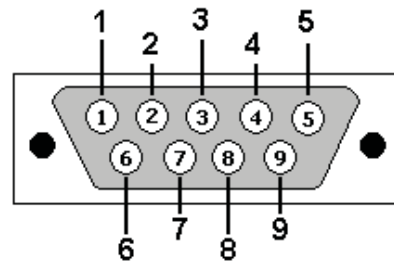

DB9 View Looking into Male Connector

**BasicATOM Pro Programming Interface Wiring Table**

DB9 Pin	Signal	In/Out	Description	Atom Pro Pin
1	DCD	In	Data Carrier Detect	NC
2	RXD	In	Receive Data	SOUT
3	TXD	Out	Transmit Data	SIN
4	DTR	Out	Data Terminal Ready	NC
5	VSS	-	Ground	VSS
6	DSR	In	Data Set Ready	NC
7	RTS	Out	Request To Send	ATN
8	CTS	In	Clear To Send	NC
9	RI	In	Ring Indicator	NC

## Electrical Characteristics

Characteristic	Value (Units)
VIN Range (min - max)	6 – 9VDC
VCC Range (min - max)	4.9 - 5.2VDC
Current Draw (Sleep mode)	10 mA
Current Draw (Idle)	20 mA
Current Draw (maximum)	50 mA
I/O Voltages (Low / High)	0.0V / 5.0V
I/O Logic	TTL
I/O Pin Assignments	P0-P7
I/O Maximum Current	3 mA sink, 3 mA source Note: Total current for all pins should not exceed 45 mA sink and 40 mA source
Memory (RAM)	2 KB
Memory (Flash)	32 KB
EEPROM Memory (For User)	0 KB
Temperature Range	-20 to +75 C

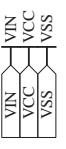
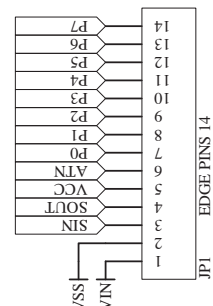
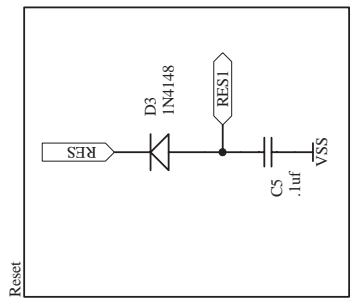
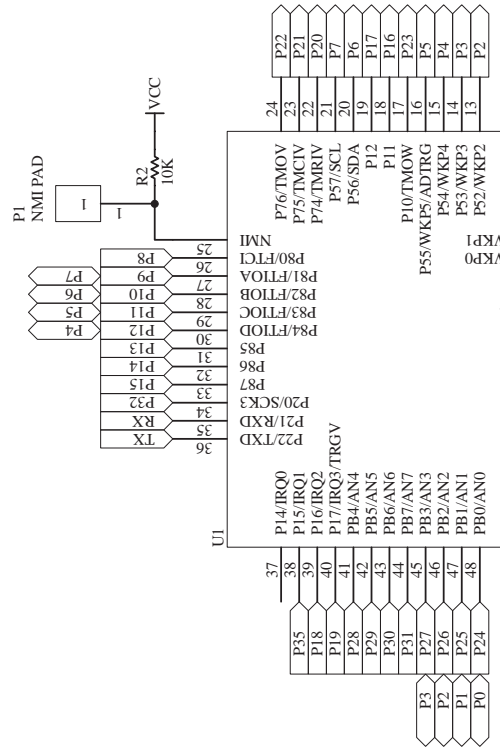
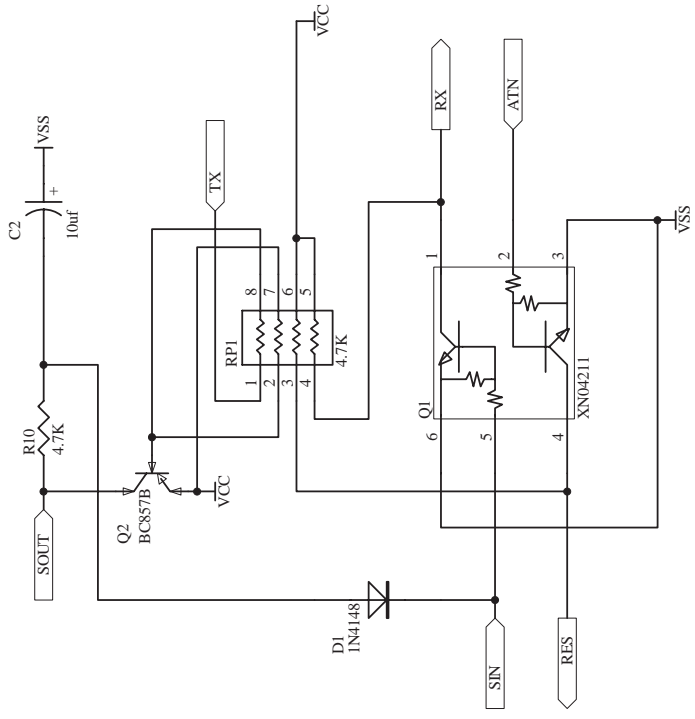
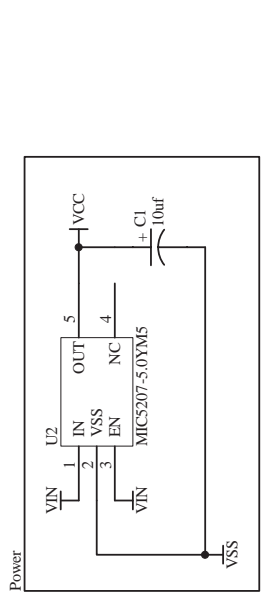

Title			
BasicATOM Pro One RevD - (c) 2008 Basic Micro Inc.			
Size	Number	Revision	
A4			
Date:	1/13/2009	Sheet of	
File:	E:\PCBdesigns\...AtomPro\ONERevD.sch	Drawn By:	Dale Kubin

**Warranty**

Basic Micro warrants its products against defects in material and workmanship for a period of 90 days. If a defect is discovered, Basic Micro will, at our discretion, repair, replace, or refund the purchase price of the product in question. Contact us at [support@basicmicro.com](mailto:support@basicmicro.com). No returns will be accepted without the proper authorization.

**Copyrights and Trademarks**

Copyright© 2009 by Basic Micro, Inc. All rights reserved. PICmicro® is a trademark of Microchip Technology, Inc. The Basic Atom and Basic Micro are registered trademarks of Basic Micro Inc. Other trademarks mentioned are registered trademarks of their respective holders.

**Disclaimer**

Basic Micro cannot be held responsible for any incidental or consequential damages resulting from use of products manufactured or sold by Basic Micro or its distributors. No products from Basic Micro should be used in any medical devices and/or medical situations. No product should be used in a life support situation.

**Contacts**

Email: [sales@basicmicro.com](mailto:sales@basicmicro.com)  
Tech support: [support@basicmicro.com](mailto:support@basicmicro.com)  
Web: <http://www.basicmicro.com>

**Discussion List**

A web based discussion board is maintained at <http://www.basicmicro.com>.

**Technical Support**

Technical support is made available by sending an email to [support@basicmicro.com](mailto:support@basicmicro.com). All email will be answered within 48 hours. All general syntax and programming questions, unless deemed to be a software issue, will be referred to the on-line discussion forums.