



BASIC MICRO

TECHNOLOGY AT WORK

BasicATOM 28-M
Data Sheet

Feature Overview:

- 14 KB of Program Space (FLASH)
- 368 Bytes of User Memory (RAM)
- 256 Bytes of User Memory (EEPROM)
- 19 Input / Output Pins
- Built-in 5V Regulator
- RS232 Port for In-Circuit Serial Programming
- Analog-to-Digital Capable I/O Pins
- Buffered Hardware Serial Port
- 2 Capture Compare
- 2 Hardware PWM
- Hardware Interrupts
- 32 Bit Floating Point Math
- 32 Bit Integer Math
- NTSC Video Display Generation
- Over 33,000 BASIC Instructions Per Second

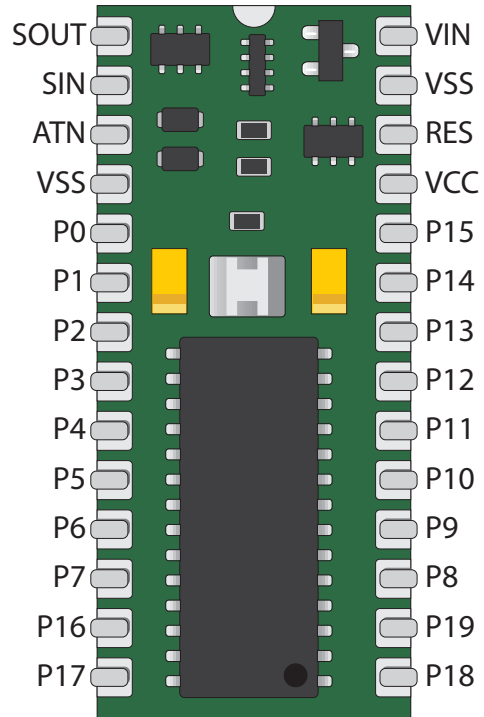

Basic Description

The BasicATOM 28-M is a self contained microcontroller designed for demanding embedded use. It is built upon the Microchip PIC16F876A (RevD Module uses PIC16F886) processor and is designed to be pin-compatible to both the BasicATOM Pro 28-M module and the Basic Stamp line of modules.

Hardware Overview:

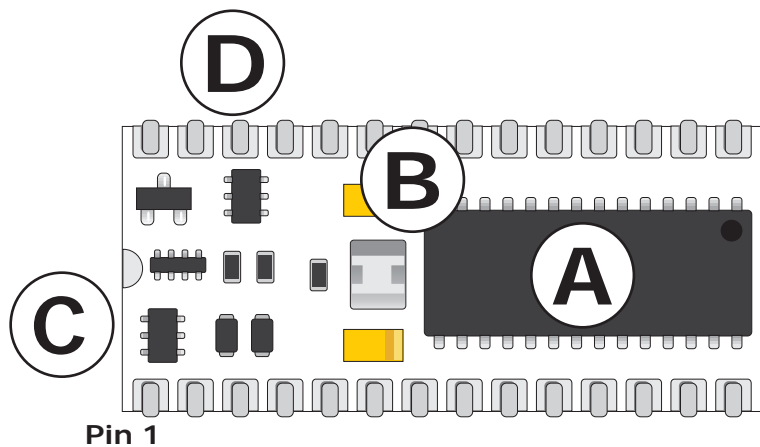

- A:** BasicATOM CPU PIC16F876A (RevD Module uses PIC16F886). Stores and executes program code.
- B:** Resonator circuit. Generates primary clock for CPU.
- C:** RS232 level shifting circuit. This allows the BasicATOM to connect directly to a PC.
- D:** Power regulator. Input 6 to 9VDC.

Pin Assignment Overview

Pin	Description
P0	<ul style="list-style-type: none"> • General purpose I/O Pin. • Individually controlled interrupt-on-change. • Individually enabled pull-up. • A/D Channel 12 (RevD Only).
P1	<ul style="list-style-type: none"> • General purpose I/O Pin. • Individually controlled interrupt-on-change. • Individually enabled pull-up. • A/D Channel 10 (RevD Only).
P2	<ul style="list-style-type: none"> • General purpose I/O Pin. • Individually controlled interrupt-on-change. • Individually enabled pull-up. • A/D Channel 8 (RevD Only). • PWM Output.
P3	<ul style="list-style-type: none"> • General purpose I/O Pin. • Individually controlled interrupt-on-change. • Individually enabled pull-up. • A/D Channel 9 (RevD Only). • Comparator C1 or C2 negative input.
P4	<ul style="list-style-type: none"> • General purpose I/O Pin. • Individually controlled interrupt-on-change. • Individually enabled pull-up. • A/D Channel 11 (RevD Only). • PWM Output.
P5	<ul style="list-style-type: none"> • General purpose I/O Pin. • Individually controlled interrupt-on-change. • Individually enabled pull-up. • A/D Channel 13 (RevD Only).
P6	<ul style="list-style-type: none"> • General purpose I/O Pin. • Individually controlled interrupt-on-change. • Individually enabled pull-up.
P7	<ul style="list-style-type: none"> • General purpose I/O Pin. • Individually controlled interrupt-on-change. • Individually enabled pull-up.
P8	<ul style="list-style-type: none"> • General purpose I/O Pin.
P9	<ul style="list-style-type: none"> • General purpose I/O Pin. • Capture/Compare/PWM2.
P10	<ul style="list-style-type: none"> • General purpose I/O Pin. • PWM Output. • Capture/Compare/PWM1.
P11	<ul style="list-style-type: none"> • General purpose I/O Pin. • SPI Clock. • I2C Clock.
P12	<ul style="list-style-type: none"> • General purpose I/O Pin. • SPI data input. • I2C Data Input / Output.

Pin	Description
P13	<ul style="list-style-type: none"> General purpose I/O Pin. SPI Data output.
P14	<ul style="list-style-type: none"> General purpose I/O Pin. EUSART asynchronous transmit. EUSART synchronous clock.
P15	<ul style="list-style-type: none"> General purpose I/O Pin. EUSART asynchronous input. EUSART synchronous data.
P16	<ul style="list-style-type: none"> General purpose I/O Pin. A/D Channel 0. Ultra Low-Power Wake-up input. Comparator C1 or C2 negative input.
P17	<ul style="list-style-type: none"> General purpose I/O Pin. A/D Channel 1. Comparator C1 or C2 negative input.
P18	<ul style="list-style-type: none"> General purpose I/O Pin. A/D Channel 2. A/D Negative Voltage Reference input. Comparator C2 positive input.
P19	<ul style="list-style-type: none"> General purpose I/O Pin. A/D Channel 3. A/D Positive Voltage Reference input. Comparator C1 positive input.
SOUT	Programming output pin (connects to RS232 RX pin).
SIN	Programming input pin (connects to RS232 TX pin).
ATN	Active-High reset signal for programming (Connects to RS232 RTS pin).
VSS	Ground (GND)
VCC	Regulated power input / output. 5VDC 50 mA output. 5VDC 100 mA input.
VIN	Unregulated power input. 9VDC maximum input.
RES	Active-low reset. Pin is pulled high internally and can be left disconnected (non-reset).

Programming Interface

The BasicATOM 28-M can be programmed from a simple RS232 serial programming interface. Only 4 connections to a RS232 DB9 cable are required.

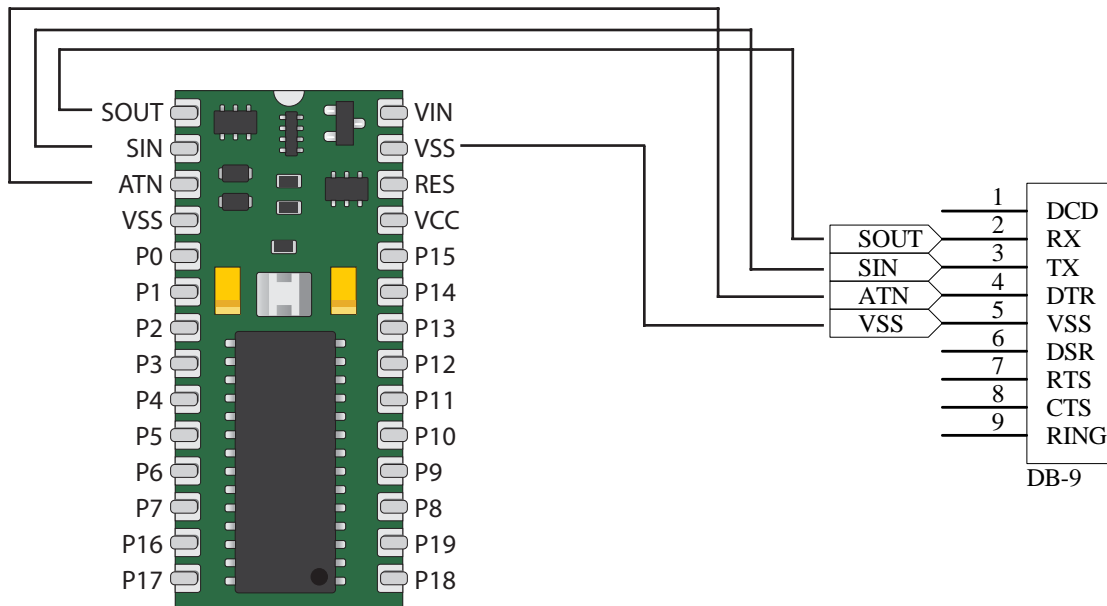

USB Programming Interface

The FTDI FT232 USB to serial microcontroller is recommended for your own custom designs requiring an USB interface. The schematic is setup for bus power. The FTDI is powered when plugged into a USB port. You will need to power the module separately through a normal power regulator.

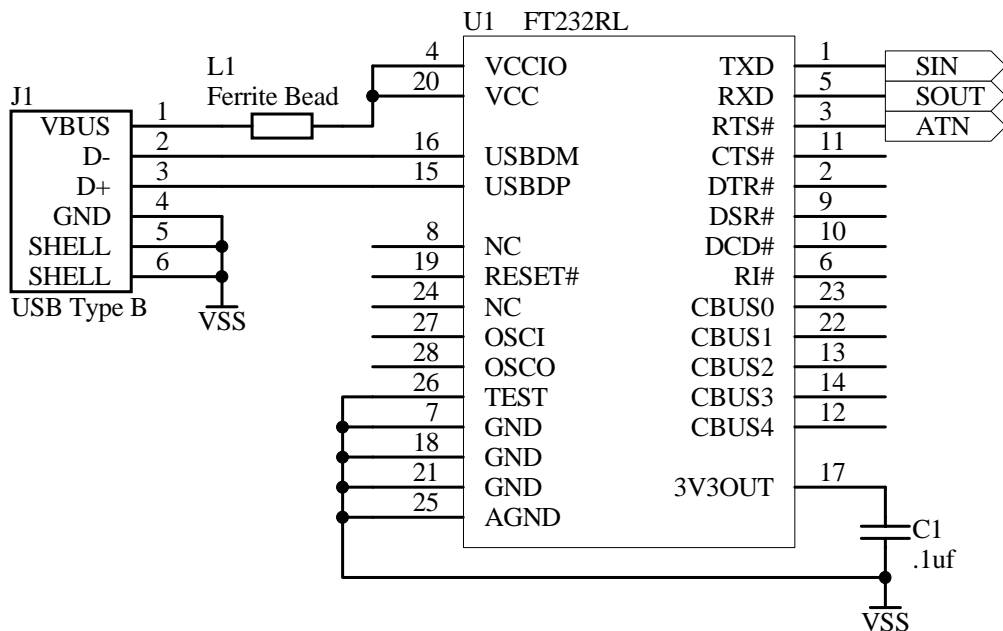

RS232 Cable Pinout

Below are pinouts for both male and female RS232 DB-9 cabling.

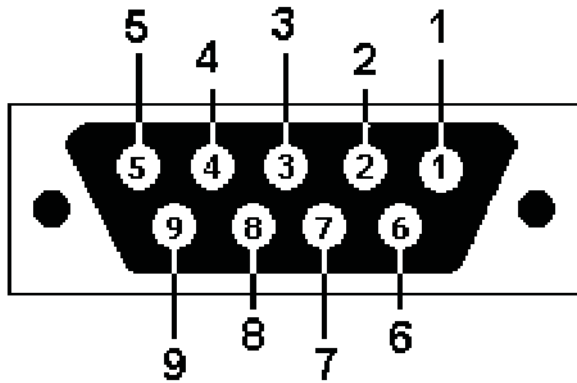

DB9 View Looking into
Female Connector

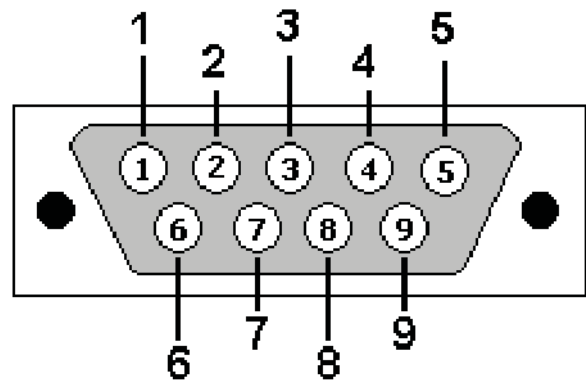

DB9 View Looking into
Male Connector

BasicATOM Programming Interface Wiring Table

DB9 Pin	Signal	In/Out	Description	Atom Pro Pin
1	DCD	In	Data Carrier Detect	NC
2	RXD	In	Receive Data	SOUT
3	TXD	Out	Transmit Data	SIN
4	DTR	Out	Data Terminal Ready	NC
5	VSS	-	Ground	VSS
6	DSR	In	Data Set Ready	NC
7	RTS	Out	Request To Send	ATN
8	CTS	In	Clear To Send	NC
9	RI	In	Ring Indicator	NC

Electrical Characteristics

Characteristic	Value (Units)
VIN Range (min - max)	6 – 9VDC
VCC Range (min - max)	4.9 - 5.2VDC
Current Draw (Sleep mode)	10 mA
Current Draw (Idle)	20 mA
Current Draw (maximum)	50 mA
I/O Voltages (Low / High)	0.0 V / 5.0 V
I/O Logic	TTL
I/O Pin Assignments	P0-P19
I/O Maximum Current	25 mA sink, 25 mA source Note: Total current for all pins should not exceed 90 mA sink and 90 mA source
Memory (RAM)	368 Bytes
Memory (Flash)	14 KB
EEPROM Memory (For User)	256 Bytes
Temperature Range	-40 to +125 C

Warranty

Basic Micro warrants its products against defects in material and workmanship for a period of 90 days. If a defect is discovered, Basic Micro will, at our discretion, repair, replace, or refund the purchase price of the product in question. Contact us at support@basicmicro.com. No returns will be accepted without the proper authorization.

Copyrights and Trademarks

Copyright© 2009 by Basic Micro, Inc. All rights reserved. PICmicro® is a trademark of Microchip Technology, Inc. The Basic Atom and Basic Micro are registered trademarks of Basic Micro Inc. Other trademarks mentioned are registered trademarks of their respective holders.

Disclaimer

Basic Micro cannot be held responsible for any incidental, or consequential damages resulting from use of products manufactured or sold by Basic Micro or its distributors. No products from Basic Micro should be used in any medical devices and/or medical situations. No product should be used in a life support situation.

Contacts

Email: sales@basicmicro.com
Tech support: support@basicmicro.com
Web: <http://www.basicmicro.com>

Discussion List

A web based discussion board is maintained at <http://www.basicmicro.com>.

Technical Support

Technical support is made available by sending an email to support@basicmicro.com. All email will be answered within 48 hours. All general syntax and programming questions, unless deemed to be a software issue, will be referred to the on-line discussion forums.