



BASIC MICRO

TECHNOLOGY AT WORK

BasicATOM Nano 40
Data Sheet

Feature Overview:

- 14 KB of program space (FLASH)
- 368 Bytes of user memory (RAM)
- 256 Bytes of user memory (EEPROM)
- 35 Input / Output Pins
- 5V Input / Output Pins
- No External Components Required
- Internal Resonator
- Analog-to-Digital Capable I/O Pins
- 2 Capture Compare
- 2 Hardware PWM
- Hardware Interrupts
- Hardware Serial up to 57600 Baud
- Hardware Serial Buffer up to 44 Bytes
- Software Serial up to 38400 Baud
- 32 Bit Floating Point Math
- 32 Bit Integer Math
- Over 13,200 BASIC Instructions Per Second

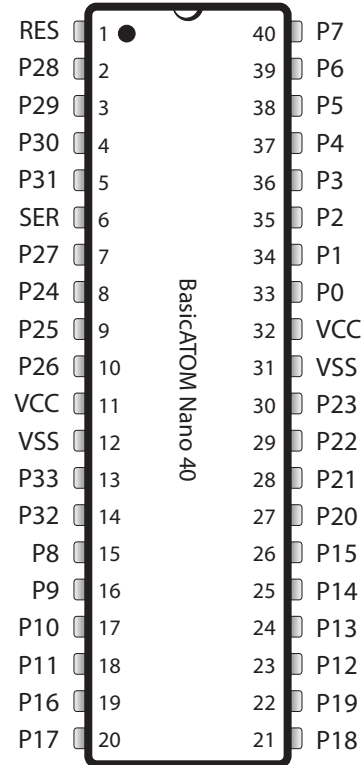

Basic Description

The BasicATOM Nano 40 is a microcontroller designed for ease of use. It is built on the Microchip PIC16F887 processor and is designed to be software compatible to both BasicATOM and Basic Stamp line of modules.

The BasicATOM Nano 40 does not require any additional component such as a resonator to run. The processor runs from an internal clock of 8 Mhz. The code is highly optimized and in most cases is faster than comparable products.

Documentation

The BasicATOM Nano 40 uses the same IDE and language as the BasicATOM modules. However timings for certain commands will be different such as SERIN and SEROUT. Refer to the manual for additional details. Most application notes or sample code for the BasicATOM can be run without modification on the BasicATOM Nano series.

Pin Name Assignment Overview

Pin Name	Description
RES	Active-low reset. Pin is pulled high with 10K pull-up to run.
SER	Programming pin. Bidirectional I/O.
VCC	Regulated 5VDC input.
VSS	Ground (GND)
P0	<ul style="list-style-type: none"> • General purpose I/O Pin. • Individually controlled interrupt-on-change. • Individually enabled pull-up. • A/D Channel 12.
P1	<ul style="list-style-type: none"> • General purpose I/O Pin. • Individually controlled interrupt-on-change. • Individually enabled pull-up. • A/D Channel 10.
P2	<ul style="list-style-type: none"> • General purpose I/O Pin. • Individually controlled interrupt-on-change. • Individually enabled pull-up. • A/D Channel 8.
P3	<ul style="list-style-type: none"> • General purpose I/O Pin. • Individually controlled interrupt-on-change. • Individually enabled pull-up. • A/D Channel 9.
P4	<ul style="list-style-type: none"> • General purpose I/O Pin. • Individually controlled interrupt-on-change. • Individually enabled pull-up. • A/D Channel 11.
P5	<ul style="list-style-type: none"> • General purpose I/O Pin. • Individually controlled interrupt-on-change. • Individually enabled pull-up. • A/D Channel 13.
P6	<ul style="list-style-type: none"> • General purpose I/O Pin. • Individually controlled interrupt-on-change. • Individually enabled pull-up. • Serial Programming Clock.
P7	<ul style="list-style-type: none"> • General purpose I/O Pin. • Individually controlled interrupt-on-change. • Individually enabled pull-up.
P8	<ul style="list-style-type: none"> • General purpose I/O Pin.
P9	<ul style="list-style-type: none"> • General purpose I/O Pin. • Capture/Compare/PWM2. • Hardware PWM Output.
P10	<ul style="list-style-type: none"> • General purpose I/O Pin. • PWM Output. • Capture/Compare/PWM1. • Hardware PWM Output.

Pin Name	Description
P11	<ul style="list-style-type: none"> • General purpose I/O Pin. • SPI Clock. • I2C Clock.
P12	<ul style="list-style-type: none"> • General purpose I/O Pin. • SPI data input. • I2C Data Input / Output.
P13	<ul style="list-style-type: none"> • General purpose I/O Pin. • SPI Data output.
P14	<ul style="list-style-type: none"> • General purpose I/O Pin. • EUSART asynchronous transmit. • EUSART synchronous clock.
P15	<ul style="list-style-type: none"> • General purpose I/O Pin. • EUSART asynchronous input. • EUSART synchronous data.
P16	<ul style="list-style-type: none"> • General purpose I/O Pin.
P17	<ul style="list-style-type: none"> • General purpose I/O Pin.
P18	<ul style="list-style-type: none"> • General purpose I/O Pin.
P19	<ul style="list-style-type: none"> • General purpose I/O Pin.
P20	<ul style="list-style-type: none"> • General purpose I/O Pin.
P21	<ul style="list-style-type: none"> • General purpose I/O Pin. • PWM output.
P22	<ul style="list-style-type: none"> • General purpose I/O Pin. • PWM output.
P23	<ul style="list-style-type: none"> • General purpose I/O Pin. • PWM output
P24	<ul style="list-style-type: none"> • General purpose I/O Pin. • A/D Channel 5.
P25	<ul style="list-style-type: none"> • General purpose I/O Pin. • A/D Channel 6.
P26	<ul style="list-style-type: none"> • General purpose I/O Pin. • A/D Channel 7.
P27	<ul style="list-style-type: none"> • General purpose I/O Pin. • A/D Channel 4.
P28	<ul style="list-style-type: none"> • General purpose I/O Pin. • A/D Channel 0.
P29	<ul style="list-style-type: none"> • General purpose I/O Pin. • A/D Channel 1.
P30	<ul style="list-style-type: none"> • General purpose I/O Pin. • A/D Channel 2.
P31	<ul style="list-style-type: none"> • General purpose I/O Pin. • A/D Channel 3.
P32	<ul style="list-style-type: none"> • General purpose I/O Pin.
P33	<ul style="list-style-type: none"> • General purpose I/O Pin.

Programming Interface

The BasicATOM Nano can be programmed using several methods. The Nano uses a single bidirectional I/O pin for programming. A typical RS232 circuit or USB to Serial adapter like the Nano USB programmer can be used.

Nano USB Programmer Interface

The Nano USB programmer only requires 3 connections. Pin 6 of the Nano which is the Serial pin, connects to the SER pin of the programmer. Pin 1 of the Nano is the RESET control pin and should be connected to the RES pin of the programmer. RES requires a 10K pullup resistor. Pin 5 of the Nano is the ground pin VSS and should be connected to a shared ground (GND) with the programmer.

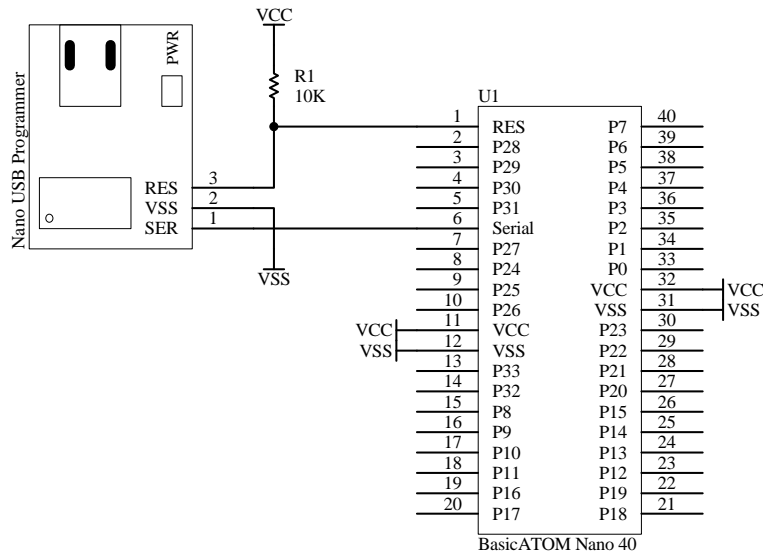

Nano RS232 Programmer Interface

The Nano uses a single bidirectional I/O pin for programming. 3 common parts are required to create the Nano programming circuit. A RS232 or USB to Serial circuit is required. The 10K resistors and diode used in the programming circuit are common and can be purchased from RadioShack.

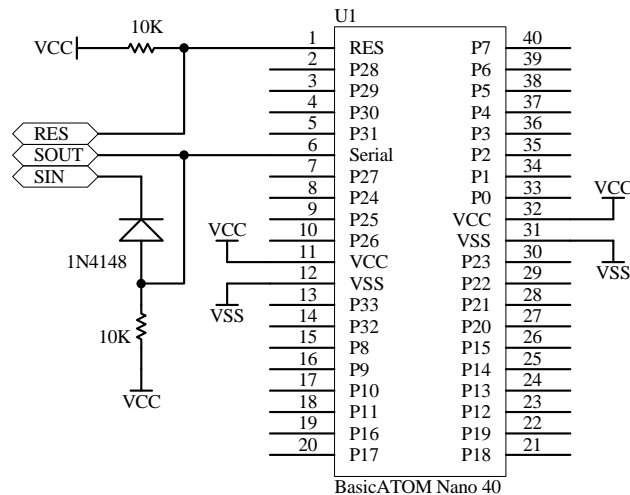

Solderless Breadboard Programmer Circuit

The Nano programming circuit is very simple and is shown on a solderless breadboard. The Nano reset pin (RES) must be pulled up with a 10K resistor and is required to run the Nano. The second resistor and diode make up the programming circuit which allows the Nano to use only one pin for programming.

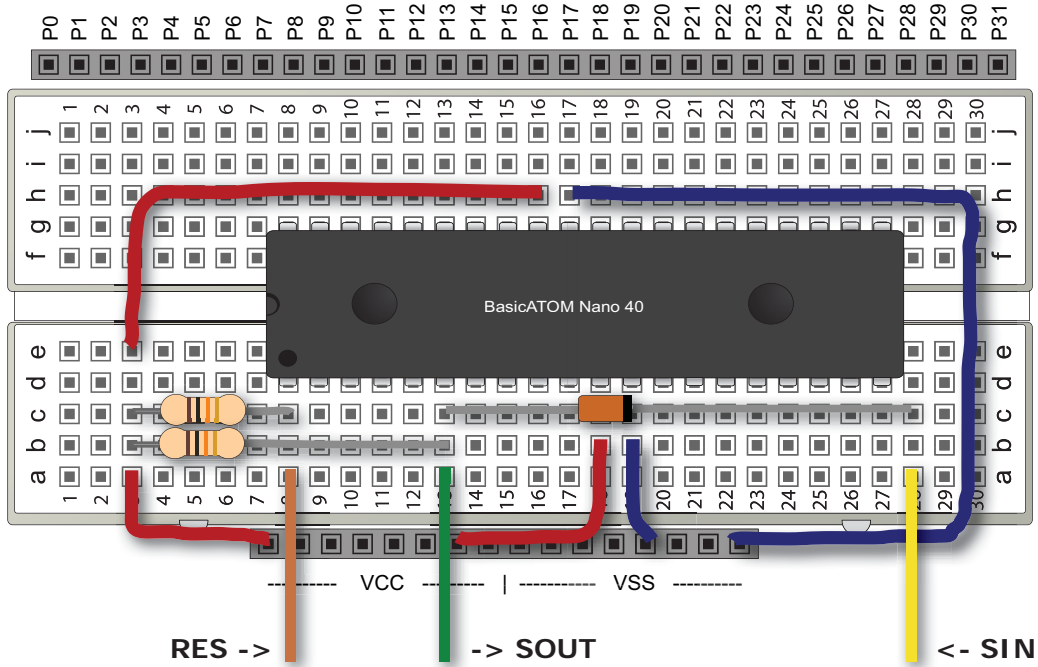

SIN, SOUT and RES

RES from the Nano must be connected to RTS of the RS232 circuit or USB to serial adapter. SOUT is connected to the RX (receive) pin and SIN is connected to the TX (transmit) pin of the RS232 circuit or USB to serial adapter.

Electrical Characteristics

Characteristic	Value (Units)
VCC Range (min - max)	4.9 - 5.2VDC
Current Draw (Sleep mode)	10 mA
Current Draw (Idle)	20 mA
Current Draw (maximum)	50 mA
I/O Voltages (Low / High)	0.0 V / 5.0V
I/O Logic	TTL
I/O Pin Assignments	P0-P33
I/O Maximum Current	25 mA sink, 25 mA source Note: Total current for all pins should not exceed 90 mA sink and 90 mA source
Memory (RAM)	368 Bytes
Memory (Flash)	14 KB
EEPROM Memory (For User)	256 Bytes
Temperature Range	-40 to +125 C

Warranty

Basic Micro warranties its products against defects in material and workmanship for a period of 90 days. If a defect is discovered, Basic Micro will, at our discretion, repair, replace, or refund the purchase price of the product in question. Contact us at support@basicmicro.com. No returns will be accepted without the proper authorization.

Copyrights and Trademarks

Copyright© 2009 by Basic Micro, Inc. All rights reserved. PICmicro® is a trademark of Microchip Technology, Inc. The Basic Atom and Basic Micro are registered trademarks of Basic Micro Inc. Other trademarks mentioned are registered trademarks of their respective holders.

Disclaimer

Basic Micro cannot be held responsible for any incidental, or consequential damages resulting from use of products manufactured or sold by Basic Micro or its distributors. No products from Basic Micro should be used in any medical devices and/or medical situations. No product should be used in a life support situation.

Contacts

Email: sales@basicmicro.com
Tech support: support@basicmicro.com
Web: <http://www.basicmicro.com>

Discussion List

A web based discussion board is maintained at <http://www.basicmicro.com>

Technical Support

Technical support is made available by sending an email to support@basicmicro.com. All email will be answered within 48 hours. All general syntax and programming questions, unless deemed to be a software issue, will be referred to the on-line discussion forums.