

Explanation

The BasicATOM28B-IC is based on the BasicATOM 28 pin module. The B version interpreter chips uses a slightly different pin configuration for S_IN / S_OUT. The BasicATOM28B-IC will not work in a circuit designed for the BasicATOM28A-IC. The BasicATOM Interpreter chip board part# B0120 is designed to work with the BasicATOM28B-IC.

Atom 28 Pin Interpreter Chip Circuit

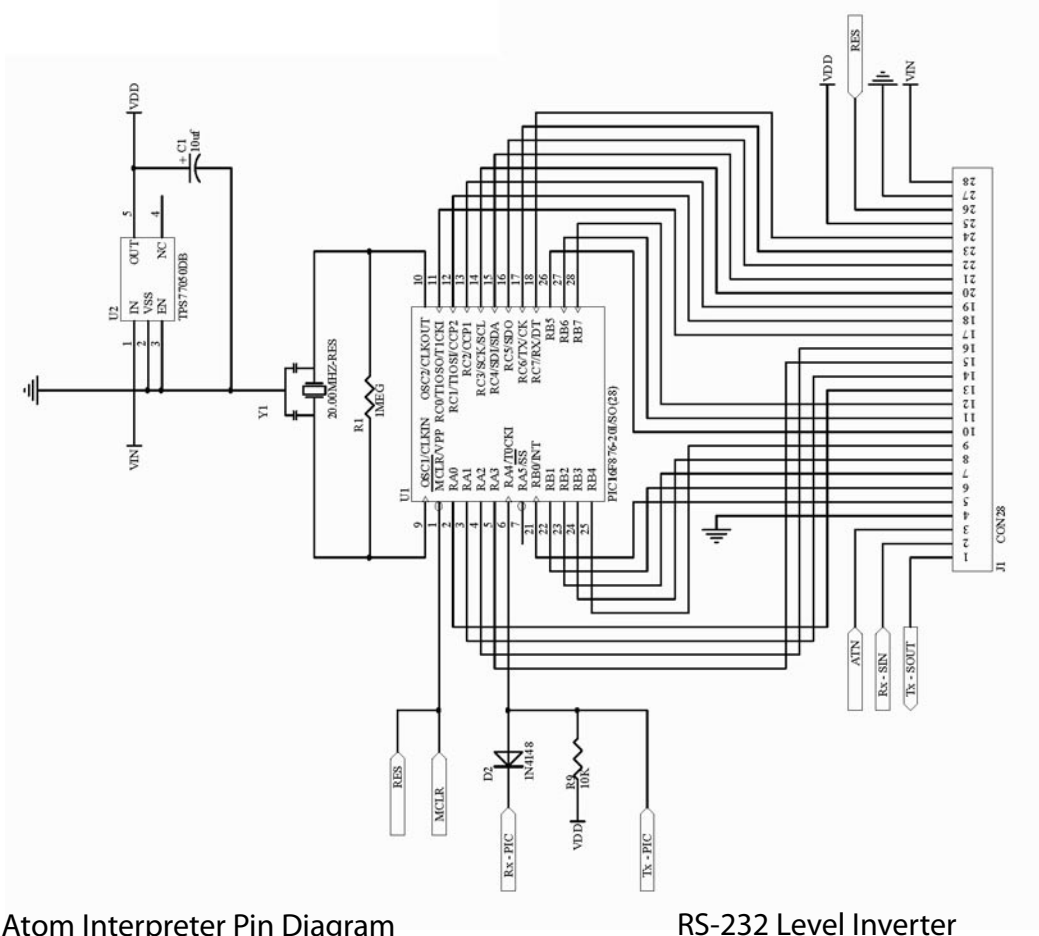

Atom Interpreter Pin Diagram

RS-232 Level Inverter

SOIC and PDIP

